

HDRP CENTRIFUGAL PUMPS FOR LOW FLOWS AND HIGH DIFFERENTIAL PRESSURES

OMEL

Established 1950

ISO 9001/2000 Certified

DESCRIPTION:

End suction, centrifugal pump type, with specially designed impellers and volute, allowing the pumps to operate continuously with small capacities against high heads, which is not possible with conventional centrifugal pumps unless controlled recirculation is used (API-610, LAST EDITION).

GENERAL DATA:

- Capacity: 0,25 to 25 m³/h.
- Heads: up to 300 m
- Maximum working pressure: up to 51 bar
- Maximum working temperature: up to 400 °C
- Minimum working temperature: up to - 100 °C

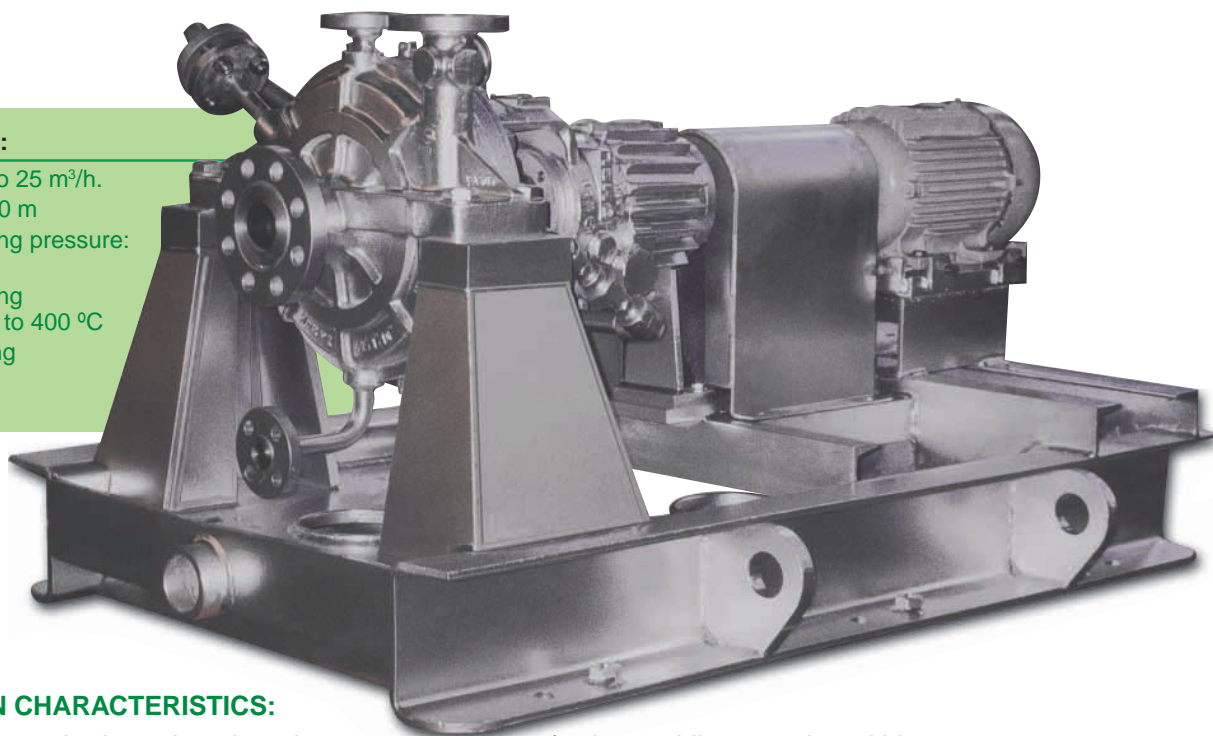

CONSTRUCTION CHARACTERISTICS:

The HDRP pumps are horizontal, end suction, centrifugal pumps with radially split housings. These pumps are of single stage design with a conventional overhung impeller. Basic construction includes a jacketed back-plate and optional cooling/heating of the bearing frame's sump. The pumps have a totally "open" radial impeller, designed to reduce axial loads to a minimum, independent of the suction pressure to which the pump is submitted.

The HDRP pumps do not use wear rings. Due to the high axial clearances, there is no risk

of seizure whilst operating within the allowable operational temperature ranges. Nine (9) pump sizes are covered by two (2) bearing frame sizes, giving the pumps maximum parts interchangeability. Pumps maintain the "back-pull-out" design for ease of maintenance. Shafts are of the "wet" design and the sealing cavity is large enough to accommodate just about any type of mechanical seal. Roller bearings support the shaft on the pump side and back-to-back mounted ball bearings on the motor side. An option for a third bearing mounted on the motor side is available for very high suction pressures.

CONSTRUCTION MATERIALS:

The HDRP range of pumps are available in all materials specified under the API 610 (Last Edition) as well as special materials upon request.

WORKING LIMITS:

PUMP TYPE	FLANGES ANSI 300 PSI/ 600 PSI		MATERIAL CLASS I-1, I-2		MAT. CLASS S-1, S-2, S-3, S-4, S-5, S-6, S-9		MATERIAL CLASS C-6		MATERIAL CLASS A-7, A-8		MAT. CL I-1, I-2	MAT. CL Steels	MAT. CL I-1, I-2	MAT. CL Steels
	INLET	OUTLET	Max. Working Pressure	Max. Testing Pressure	Max. Working Pressure	Max. Testing Pressure	Max. Working Pressure	Max. Testing Pressure	Max. Working Pressure	Max. Testing Pressure	Max. Suction Pressure	Max. Suction Pressure	Max. Working Temp.	Max. Working Temp.
	ANSI	ANSI	BAR	BAR	BAR	BAR	BAR	BAR	BAR	BAR	BAR	BAR	°C	°C
HDRP	2"	1"	21	31,5	51	76,5	51	76,5	42,5	64	15	30	180	400

DIMENSIONS:

Subject to change without notice.

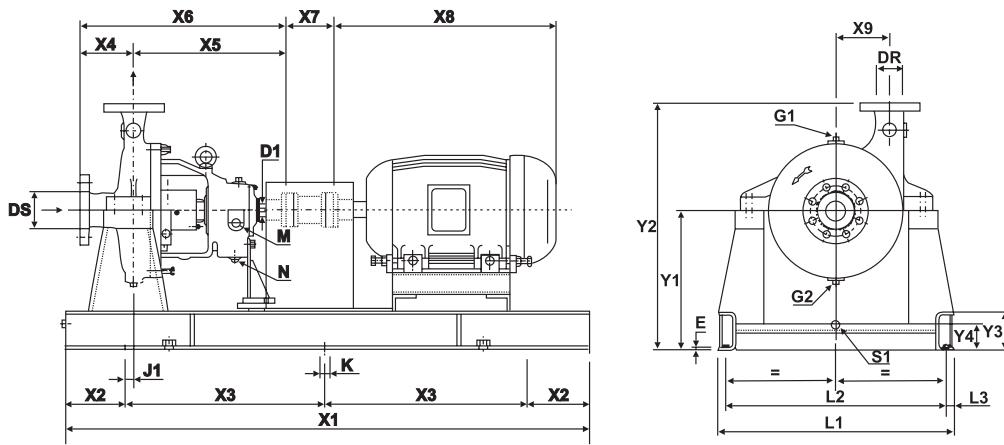

PUMP SIZE	FLANGES		X4	X5	X6	X7	X8	X9	Y2	D1 PUMP	WEIGHT
	IN (DS)	OUT (DR)									
2"x 1"x 7" A 2"x 1"x 7" B 2"x 1"x 7" C	2"	1"	135	554	689	140	VARIES WITH MOTOR FRAME SIZE SELECTED	107	640	35	87 Kg
2"x 1"x 10" A 2"x 1"x 10" B 2"x 1"x 10" C											
2"x 1"x 13" A 2"x 1"x 13" B 2"x 1"x 13" C											

CONNECTIONS		
M	ø 1/2"	INLET AND OUTLET FOR COOLING OF THE BEARING FRAME
N	ø 3/8"	DRAIN PLUG - FOR BEARING FRAME
G1	ø 1/2"	VENT.
G2	ø 1/2"	DRAIN-PUMP

FRAME SIZE	BASE FRAME DIMENSIONS													
	J1	ø K	X1	X2	X3	E	S1	Y1	Y3	Y4	L1	L2	L3	APPROX.
API-0,5	48	1"	1232	152	464	3/8"	ø2"NPT	440	155	80	762	686	38	180 kg
API-1	48	1"	1536	152	616	3/8"	ø2"NPT	440	155	80	762	686	38	215 kg
API-1,5	48	1"	1842	152	769	3/8"	ø2"NPT	440	155	80	762	686	38	260 kg
API-2,0	48	1"	2146	152	921	3/8"	ø2"NPT	440	155	80	762	686	38	300 kg

PUMP SIZE	MOTOR FRAME SIZE vs. REQUIRED BASE FRAME SIZE											
	71	80	90 S/L	100 L	112 M	132 S/M	160 M/L	180 M/L	200 M/L	225 S/M	250 S/M	280 S/M
2"x 1"x 7" A	API-0,5	API-0,5	API-0,5	API-0,5	API-0,5	API-0,5						
2"x 1"x 7" B	API-0,5	API-0,5	API-0,5	API-0,5	API-0,5	API-0,5						
2"x 1"x 7" C		API-0,5	API-0,5	API-0,5	API-1	API-1	API-1					
2"x 1"x 10" A		API-0,5	API-0,5	API-0,5	API-1	API-1	API-1					
2"x 1"x 10" B		API-0,5	API-0,5	API-0,5	API-1	API-1	API-1					
2"x 1"x 10" C			API-0,5	API-0,5	API-1	API-1	API-1	API-1,5	API-1,5			
2"x 1"x 13" A				API-0,5	API-1	API-1	API-1	API-1,5	API-1,5	API-1,5		
2"x 1"x 13" B				API-0,5	API-1	API-1	API-1	API-1,5	API-1,5	API-1,5	API-1,5	API-2,0
2"x 1"x 13" C				API-0,5	API-1	API-1	API-1	API-1,5	API-1,5	API-1,5	API-1,5	API-2,0

